

Jeannie Carmichael Ball & Brunch 2017

1 HOOPER'S JIG J32 · 3/4L

Miss Milligan's Miscellany of Scottish Country Dances · Crib: Eric Ferguson's E-cribs · Diagram: Keith Rose's Diagrams

- 1- All clap, 1c cross Rsh and cast off one (2c up) ; 1c+3c RHA
- 9- All clap, 1c cross back Rsh, cast up to own place (2c down) ; 1c+2c LHA
- 17- 1M+3W change places RH | 1W+3M change RH, **while{2}** 1M+3W dance a Rsh loop ; 1M+3W cross back RH **while{2}** 1W+3M loop | 1W+3M cross back LH, 1W to 2pl **while{2}** 1M casts to 2pl (2c up)
- 25- 2c+1c R&L

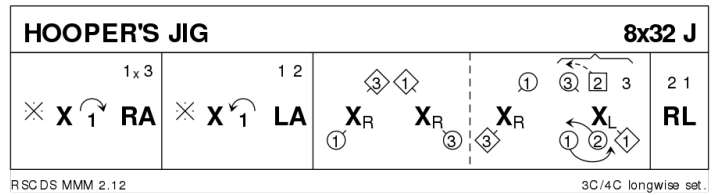

2 DAVY NICK NACK R32 · 3/4L

Robert M Campbell: The Geneva Park Dances Part 1 (Campbell) · Crib: Eric Ferguson's E-cribs · Diagram: Keith Rose's Diagrams

- 1- 1c+2c+3c cross over RH, set ; repeat
- 9- 1c 1½ RH turn ; cast off one place, turn LH to finish facing 1cnrs
- 17- 1c change places RH with 1cnrs, set to cnrs ; change place RH, turn LH to face 2cnrs
- 25- 1c change places RH with 2cnrs, set to cnrs ; change places RH, cross over LH.

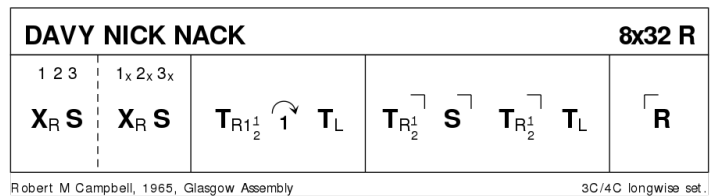

3 FAIR DONALD S32 · 3/4L

RSCDS XXIX 4 · Crib: Eric Ferguson's E-cribs · Diagram: Keith Rose's Diagrams

- 1- 1c dance NHJ between 2c and cast up to top ; dance NHJ between 3c and cast up to 1cnrs (2c up on [7-8])
- 9- Reel4 with 1cnrs, at the end pass Lsh to face 2cnrs
- 17- Reel4 with 2cnrs, finishing between 2c on own side, facing up NHJ
- 25- 1c cast off one | 2c+1c+3c set ; all turn P BH

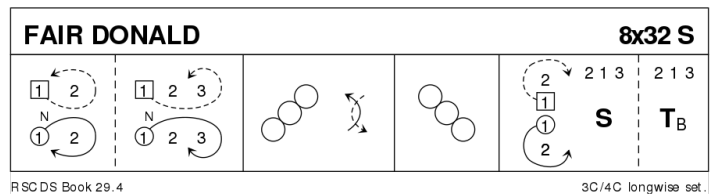

4 NEIL M GRANT J32 · 3/4L

Christine Grant: RSCDS XLIX 1 · Crib: Eric Ferguson's E-cribs · Diagram: Keith Rose's Diagrams

- 1-- 1c cross RH | cast off (2c up) ; ½ Fig8 R (round 3c) to join with P LH and 1c) RH
- 9-- The Spoke: BiL{1}, advance LHJ cclw to next c) {1} | repeat 3 times, finish facing 1c)
- 17-- 1c+1c) ½ diag Reel4, pass Rsh ; 1c+2c) ½ Diag Reel4 (3x,1x,2x)
- 25-- all chase c)w half round ; teapots R (2,1,3)

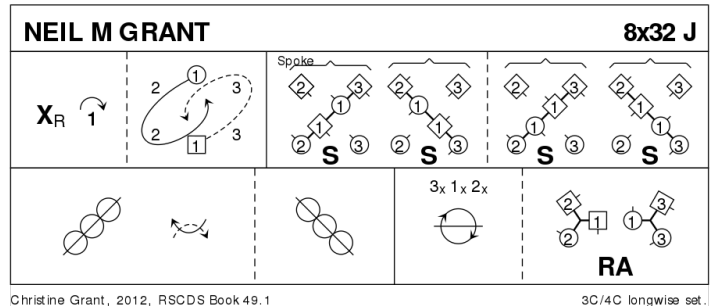

5 SWISS LASSIE R32 · 3/4L

Rosi Betsche: RSCDS XXXIX 1 · Crib: Eric Ferguson's E-cribs · Diagram: Keith Rose's Diagrams

- 1-- 1c cast off 2 (dance in to begin) (2c+3c up) ; 2c+1c 1¼ turn RH to midline, facing P
- 9-- 2c+1c Reel4 on midline, 2M and 1W end facing opposite side, with P behind
- 17-- 2c & 1c chase c)w round 3c to (1,3,2) ; All A&R
- 25-- 3c+2c turn RH ½, leading into ½ RHA, to sidelines ; 1c+2c repeat (2,1,3)

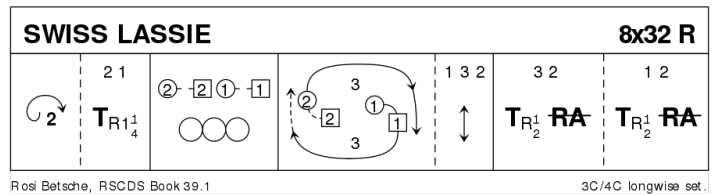

6 THE ROSE OF THE NORTH S32 · 3/4L

Roy Goldring: Silver Jubilee 25 - Leeds Branch · Crib: Eric Ferguson's E-cribs · Diagram: Keith Rose's Diagrams

- 1-4 1c lead down, cross below 3c and cast up into 2plx (2c up)
- 5-16 2c+1c+3c R&L for 3 couples
- 17-- 1c set to and turn corners, to finish BtoB in the centre, 1M facing up, 1W facing down
- 25-- 1M+2c & 1W+3c Circle3 L (at end 1c pull Rsh back to face P) ; 1c set, petronella to 2pl

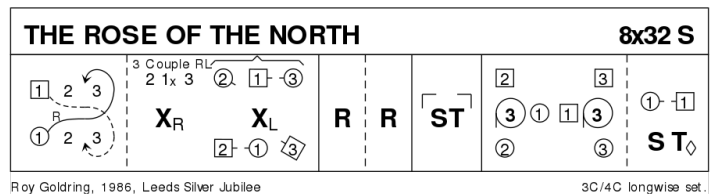

7 THE INIMITABLE DEREK R32 · 3/4L

Roy Goldring: Magazine Dances 2005-2009 · Crib: Eric Ferguson's E-cribs · Diagram: Keith Rose's Diagrams

- 1- 1W+2W & 1M+2M turn 1¼ EH, 1c starting inwards, into line across with 1c BtB in the middle | 1c+2c set ; turn with the other hand ¾ (1c starts up) to (2,1,3), 2c facing out
- 9- Opposing Reels3 on the sides, 1c start to the R (1M Rsh to 3M, 1W Rsh to 2W), on [13-14] 1c cross to »2cnr position, on [15-16] 1c turn 2cnr persons (2W and 3M) RH into 2diagonal line
- 17- 1c+2cnrs BiL | 1c turn LH to join 1cnr with RH ; BiL | 1c turn LH to finish side by side in the centre, 1W facing up, 1M down
- 25- 1W+2W+3W & 1M+2M+3M RHA ; 1M+1W dance out the end and cast R into (2,1,3)

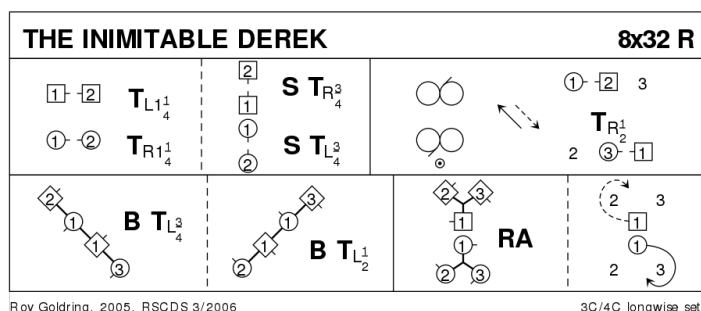

8 SWIRLING SNOW S32 · 3/3L

Ruth Taylor (CAN): Martello Tower Book 7 · Crib: MiniCribs · Diagram: Keith Rose's Diagrams

- 1-8 1s cross RH & cast 1 place, 1s dance down between C3 & cast to 2nd place opposite sides
- 9-16 All 1/2 turn & twirl to change places, all turn RH into allemande hold (2s & 3s face down, 1s face up)
- 17-24 All dance interlocking Allemandes:
1s dance normal Allemande ending in 2nd place **while** 2s+3s Allemande (down) & up to 3rd/1st places. (3)1(2)
- 25-32 1s dance 1/2 Fig of 8 up between 3s, all turn 2H 1.1/2 times to own sides to end 3 1 2

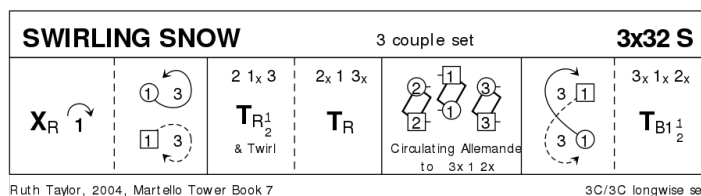

9 CADGERS IN THE CANONGATE R48 · 3/4L

Walsh (18C): RSCDS IX 10 · Crib: Eric Ferguson's E-cribs · Diagram: Keith Rose's Diagrams

- 1- 1c Rsh Reels3 on opposite sides, 1M starts across top (Rsh to 2W), 1W crosses down (Lsh to 3M) (to 1x,2,3)
- 9- 1c Rsh Reels3 on own sides, 1W starts across top, 1M crosses down, end in 1pos NHJ (1,2,3)
- 17- 1c NHJ set to 2W | move round in PdB to face 2M ; set to 2M | retire in PdB to 1pl
- 25- 1c+2c set | ½ RHA ; set | ½ LHA to places
- 33- 1c cross RH | cast off one (2c up) ; 1c turn LH 1½ (to 2,1,3)
- 41- 2c+1c R&L.

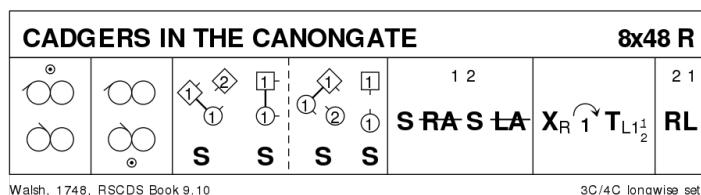

Alternative for [1-8]: 1c ends on own side. See 101 SCD and Manual

10 BREAK

11 THE LADY WYND J32 · 3/4L

Roy Goldring: Graded and Social Dances 2 - 23 Dances · Crib: Eric Ferguson's E-cribs · Diagram: Keith Rose's Diagrams

- 1- 1c long cast (2c up) ; all turn RH and face up for
- 9- 2c+1c+3c promenade (2,1,3)
- 17- 1c Fig8 on own side, starting to the R
- 25- Teapots R and L (RHA with end couple on the R ; LHA with end couple on the L)

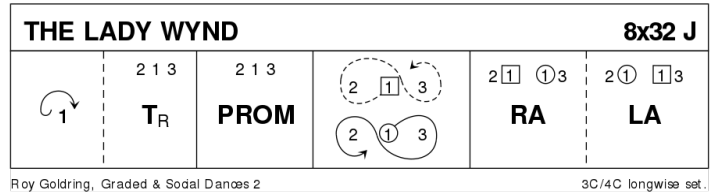

12 THE SAILOR R32 · 3/4L

RSCDS XXIV 4 · Crib: Eric Ferguson's E-cribs · Diagram: Keith Rose's Diagrams

- 1- 1c cross down RH (2c up) to 2plx and BiL with cnrs ; 1c cast R into lines across | all set
- 9- All Reels3 across, Rsh to 1cnr, finishing (2,1x,3)
- 17- 1c lead down | lead to the top ; cross and cast to (2,1,3)
- 25- 2c+1c R&L.

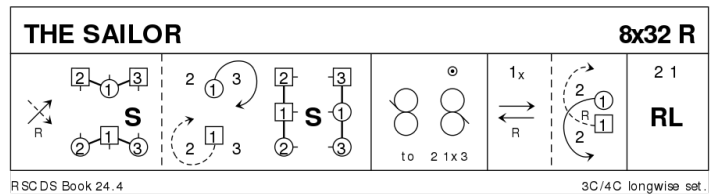

Note: [3-4] is NOT in DTr position.

13 THE CRAVEN STRATHSPEY S32 · 3/4L

Derek Haynes: Carnforth Collection of SC Dances 1 · Crib: Eric Ferguson's E-cribs · Diagram: Keith Rose's Diagrams

- 1- 1c+2c Poussette
- 9- 1c+2c S&Link ; Circle4 L (2,1,3)
- 17- Reels3 on own side (1c Rsh to 2c), at end 2W loops R into
- 25- 2c+1c RHA (1M face out for) ; 1c+3c LHA

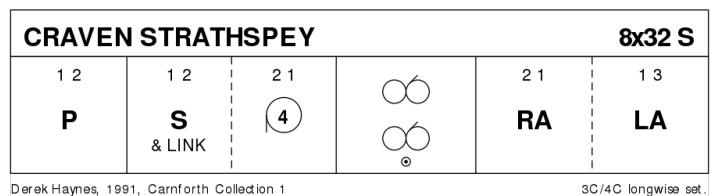

14 JOHN CASS J32 · 5/5L

Peter Avery: RSCDS XLIX 10 · Crib: Eric Ferguson's E-cribs · Diagram: Keith Rose's Diagrams

- 1-- 1c lead down (2c+3c up) ; lead up to 3pl and turn RH to face out on M side giving Rsh to 3M, 1W behind 1M
- 9-- 2M+3M & 1c & 4W+5W diag. Reel3, all cpls lead-change at both ends, 1c finish giving Lsh to 4M, 1W behind 1M
- 17-- 2W+3W & 1c & 4M+5M diag. Reel3, all cpls lead-change at both ends, 1c finish in 3pl facing down NHJ
- 25-- 1c dance between 4c, cast behind 5c (4c+5c up) ; 1c pivot turn with R elbow grip (2,3,4,5,1)

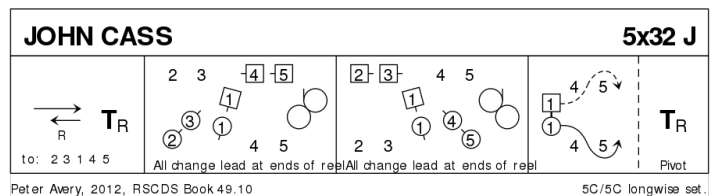

15 THE CLANSMAN R32 · 2/4L

Derek Haynes: RSCDS XXXII 8 · Crib: Eric Ferguson's E-cribs · Diagram: Keith Rose's Diagrams

- 1- 1c cross RH | cast off (2c up) ; 2c+1c ½ RHA | set to P (1,2x)
- 9- 1c+2c R&L, finish with ¾ LH turn into line across, the W in the centre:
- 17- The Targe (1W+2W turn ¾ RH while {2} 1M+2M chase ¼ round cclw | 1M+2W & 1W+2M Turn LH ; repeat) finishing on sides (2,1x)
- 25- 2c facing 1c set | all set to P ; 1c lead up, cross and cast to 2pl (2,1)

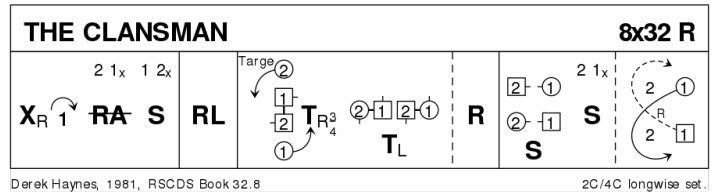

16 DELVINE SIDE S32 · 3/4L

William (18C) Campbell: RSCDS II 9 · Crib: Eric Ferguson's E-cribs · Diagram: Keith Rose's Diagrams

- 1- 1c+2c set | cross Rsh (no hands) ; repeat
- 9- 1c down the middle and up, 2c step in
- 17- 1c+2c Allemande, finish facing 1cnr
- 25- 1c turn 1cnr BH, pass Rsh, turn 2cnr BH, cross Rsh to (2,1,3)

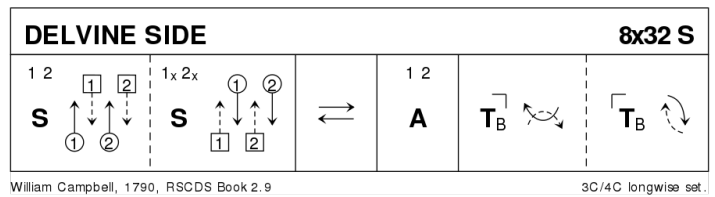

Note: older instructions tell 1c to turn once LH on 23-24; the current (revised) instructions leave that unspecified.

17 FUGAL FERGUS J48 · 3/4L

Hugh Foss: Magazine Dances 2005-2009 · Crib: Eric Ferguson's E-cribs · Diagram: Keith Rose's Diagrams

This dance is a fugue; the M copy the W 8 bars later.

1W+2W+3W dance:

- 1- Across the top and behind the men to own places
- 9- Set | cross ; set | cross
- 17- Set | cross RH ; chase clw round top to places (3,2,1)
- 25-40 1½Reel3 on own side (2W starts out and down) {12 bars} ; 1W+2W turn LH 1½ (to 2,1,3)
- 41- stand

while{48}

- 1- 1M+2M+3M stand
- 9-48 the M repeat the W's movements in mirror image 8 bars later, giving RH on [19-20].-On [28] the M pass just below their P who is 4 bars into the reel, and face up .

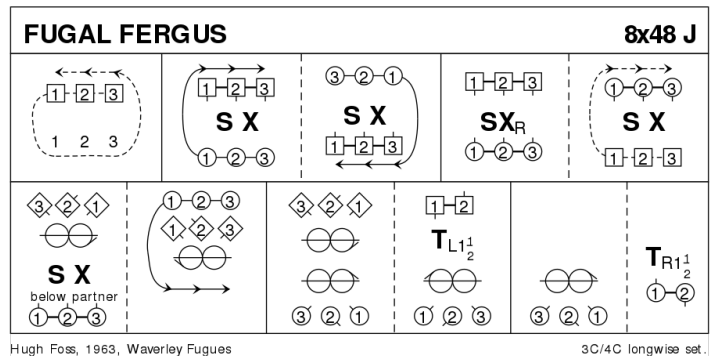

18 WAVERLEY J48 · 3/4L

Button and Whittaker: RSCDS XV 12 · Crib: Eric Ferguson's E-cribs · Diagram: Keith Rose's Diagrams

- 1– 1W followed by 2W+3W chase cclw behind 1M+2M+3M to places
- 9– 1M followed by 2M+3M repeat clw round the W
- 17– 1c facing 2c set | change place RH ; set | change place LH ready for
- 25– 1c+2c Poussette, 1c finish BtoB in the middle facing own side for
- 33– DTr, 1c finish facing W side NHJ 1W above 1M
- 41– 1c dance out between 2W & 3W, 1W casts up and 1M casts down, meet in the middle ; cast as before, between 2M & 3M, finish in 2pl

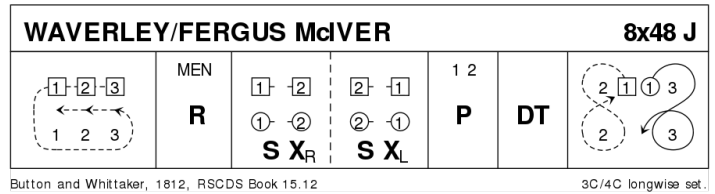

19 BARBARA'S STRATHSPEY S32 · 3/4L

Sue McKinnell: RSCDS XLVI 4 · Crib: Eric Ferguson's E-cribs · Diagram: Keith Rose's Diagrams

- 1– 1c set | cast (2c up) ; ½ Fig8 L (2,1x,3)
- 9– All set | 1c cross Rsh ; 1c+3c turn RH 1½ (to 1,2,3 on M side, 2,3,1 on W side)
- 17– 3C Bourrel: 2W+3M chase cclw half round to midline **while**{4} 1M+3W & 2M+1W set adv | turn BH ¾ and pivot R, all facing P on midline (3,1,2) ; All set | All C turn BH ¾ to sidelines
- 25– All chase clw ½ round ; all turn P RH ½ and twirl R to (2,1,3)

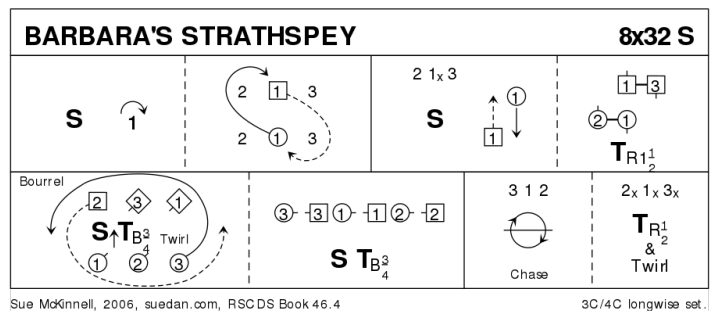

20 THE REEL OF THE 51ST DIVISION R32 · 3/4L

James Edward McCartney Atkinson: RSCDS XIII 10 · Crib: Eric Ferguson's E-cribs · Diagram: Keith Rose's Diagrams

- 1– 1c set | cast off two places (2c up) and lead up to 1cnrs
- 9– 1c set to 1c nr | turn 1c nr RH and join LH in the middle ; BiL | turn 1¼ LH to 2cnrs
- 17– Repeat with 2cnrs | cross to (2,1,3)
- 25– 2c+1c+3c circle6 and back.

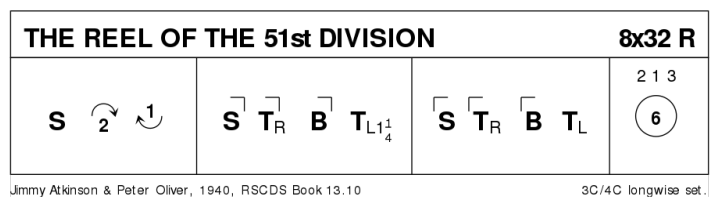

21 BRUNCH

22 THE HOLLIN BUSS J32 · 2/4L

RSCDS XXIV 8 · Crib: Eric Ferguson's E-cribs · Diagram: Keith Rose's Diagrams

- 1- 1c+2c A&R ; Turn RH ½ into | ½ RHA (2,1)
- 9- 2c+1c A&R ; Turn LH ½ into | ½ LHA (1,2)
- 17- 1c (BHJ) slip down the middle and up
- 25- 1c set | cast off (2c up) ; 2c+1c turn RH

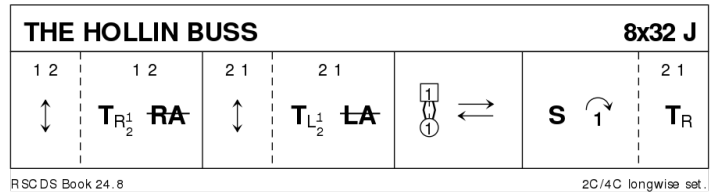

23 THE SHORES OF SOLWAY S32 · 3/4L

Roy Goldring: 10 Social Dances · Crib: Eric Ferguson's E-cribs · Diagram: Keith Rose's Diagrams

- 1- 1c long cast to 3pl (2c+3c up) ; 2c repeat (3,1,2)
- 9- 3c+1c+2c The Knot, 1c face 1cnr
- 17- 1c set to 1cnr | dance round P Rsh ; set to 2cnr | dance round P to (2,1,3)
- 25- Circle6 and back (2,1,3)

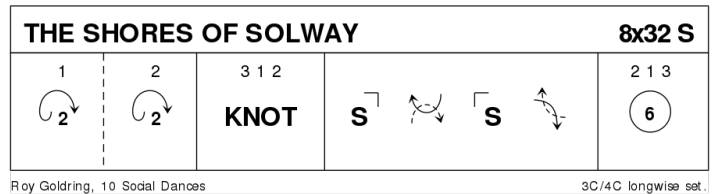

24 RED HOUSE R40 · 2/4L

Playford: RSCDS VII 2 · Crib: Eric Ferguson's E-cribs · Diagram: Keith Rose's Diagrams

- 1- 1c set and cast off one ; set and cast back
- 9- 1M cast off (1W follows) behind 2M, between 2c, behind 2W and cross to finish below 2M/2W
- 17- 1W cast up (1M follows) behind 2W, between 2c, behind 2M and cross to finish 1c in own places
- 25- 1c+2M Reel3 on M sideline (1M & 2M begin Lsh, 1W entering below them ; 1M+2M end in exchanged places, 1W in own place
- 33- 1c+2W Reel3 on W sideline (1W & 2W begin Rsh, 1M entering below them, finish (2,1)

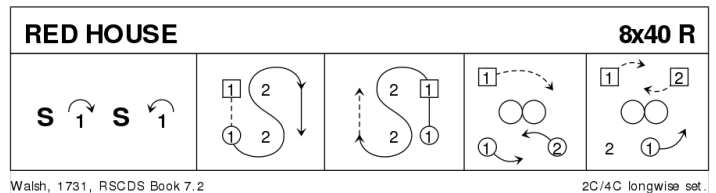

25 FAIR JENNY'S JIG J32 · 3/4L

Ron Wallace: From the Redwood Forest · Crib: Eric Ferguson's E-cribs · Diagram: Keith Rose's Diagrams

- 1- 1c set | cast off one (2c up) ; set | turn RH ½ to face 1cnrs
- 9- Turn 1cnr LH | P RH ; 2cnr LH | P RH to 2pl facing out.
- 17- Reels3 on own sides, 1c Rsh to 3cnr, ending BtoB in the centre for
- 25- 2c+1c+3c DTr.

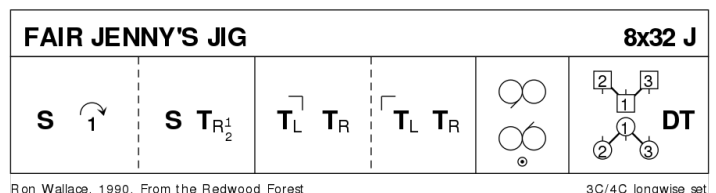

26 BROADWAY S32 · 3/3L

Chris Ronald: *The Sunday Class Dance Book 2 · Crib: Eric Ferguson's E-cribs · Diagram: Keith Rose's Diagrams*

- 1-- 1c dance down | turn BH ; dance up and cast to 2pl (2c up) (2,1,3)
 9-- S&Link3 into lines across ; Half Diag R&L to the L (in each line only the middle and RH persons dance)
 17-- S&Link3 to sidelines; Half Diag R&L to the L (in each line only the middle and RH persons dance) (3x,1x,2x)
 25-- All set | All turn P ½ and twirl to sideline | All set

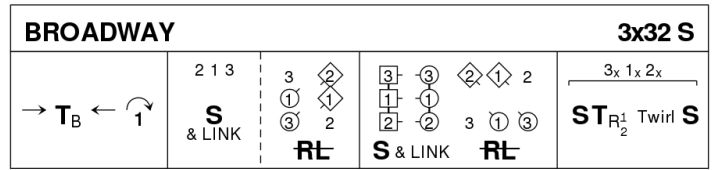

Chris Ronald, 2003, Big Apple Collection

3C/3C longwise set.

27 THE HIGHLANDMAN KISSED HIS MOTHER R32 · 3/4L

Miss Milligan's *Miscellany of Scottish Country Dances · Crib: Eric Ferguson's E-cribs · Diagram: Keith Rose's Diagrams*

- 1-- 1c turn RH | cast off (2c up) ; turn LH 1½ to face 1cnrs
 9-- 1c set to and turn corners, finish facing 1cnrs
 17-- Reels3{6} with corners, Lsh to 1cnr | 1c cross own side
 25-- 2c+1c+3c circle6 and back

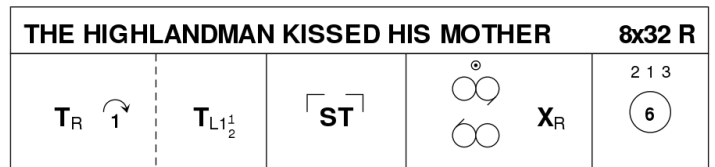

RSCDS MMM 1.20

3C/4C longwise set.

28 BREAK

29 MRS STEWART'S JIG J32 · 3/4L

Frans Ligtmans: *RSCDS XXXV 1 · Crib: Eric Ferguson's E-cribs · Diagram: Keith Rose's Diagrams*

- 1-- 1c set | 1W casts, 1M following, round 3W, 1W dances up round 3M and 1M dances up the middle, 1c face 3c (2c up on 7-8) (2,1x,3)
 9-- 2c+1c+3c G-Chain (2c cross), 2M+1M finish facing out
 17-- 2c+1c L-Chain
 25-- 2c+1c+3c A&R ; 1c turn RH 1½ to (2,1,3)

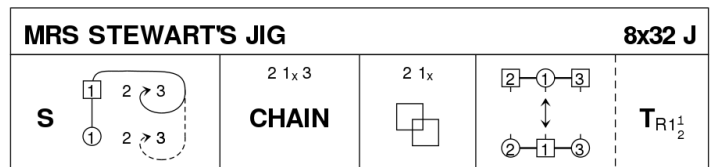

Frans Ligtmans, 1986, RSCDS Book 35.1

3C/4C longwise set.

30 ANNA HOLDEN'S STRATHSPEY

S32 · 2/4L

John Drewry: RSCDS XLII 2 · Crib: Eric Ferguson's E-cribs · Diagram: Keith Rose's Diagrams

- 1- 1c+2c RHA (2c face out) ; 1c cross down, **while**{2} 2c cast up | 1M+2W & 2M+1W Turn ¾ easy hand to line4 across facing down (1c between 2c)
- 9- All dance down, on [12] 1c turns in and 2c meets, all NHJ ; 1c+2c dance up | 1c cast off to 2plx, **while**{2} 2c dance to 1pl (loop is usual)
- 17- All set | »petronella in tandem« ; repeat (to 1,2x)
- 25- All set | ½ Circle4 Left ; 1c turn BH 1½ to 2pl.

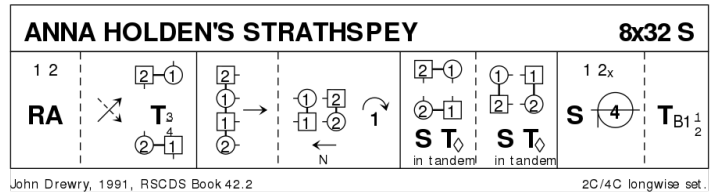

31 WICKED WILLY

R32 · 4/4L

Harry C Ways: Bicentennial Book plus Seven SCD · Crib: Eric Ferguson's E-cribs · Diagram: Keith Rose's Diagrams

- 1- 1c+4c cross RH and cast in (2c+3c step out), ½ Fig8 outwards, finish all BtoB in the centre facing nearest cnr
- 9- 1c+4c double
»Hello&Goodbye« setting, finish opposite the diagonally opposite corner
- 17- 1c+4c turn this cnr RH ; LHA in the middle to sides (to 2,4x,1x,3)
- 25- 1c+3c ½R&L ; 4c+3c ½R&L (to 2,3,4,1)

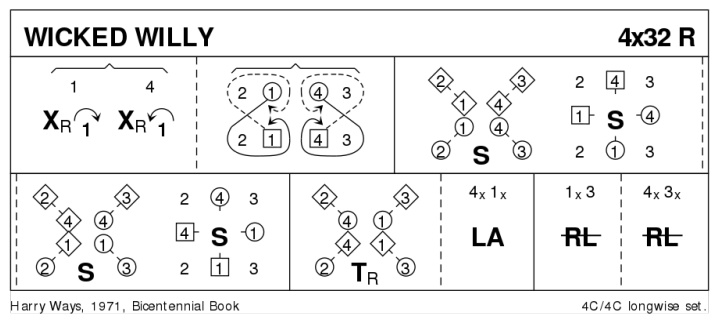

32 WELCOME TO AYR

J32 · 3/4L

Jill Hendricksen/Kathy Stewart: RSCDS XLVII 8 · Crib: Eric Ferguson's E-cribs · Diagram: Keith Rose's Diagrams

- 1- 1c+2c DblFig8, 1c crossing down to start, at end 2c face out
- 9- 1c+2c turn EH 1¼ on side (2c to 1pl) and 1c face down NHJ ; 1c dance down and turn 3c EH, 3c finish in 3pl and 1c facing 1cnr
- 17- 1c+1cnrs ½ diag. Reel4 and pass Rsh ; repeat with 2cnrs, 1c finish on midline Lsh to Lsh facing own side
- 25- 3c+1M & 1W+2c RHA (3x,1x,2x) ; All chase clw ½ round (2,1,3)

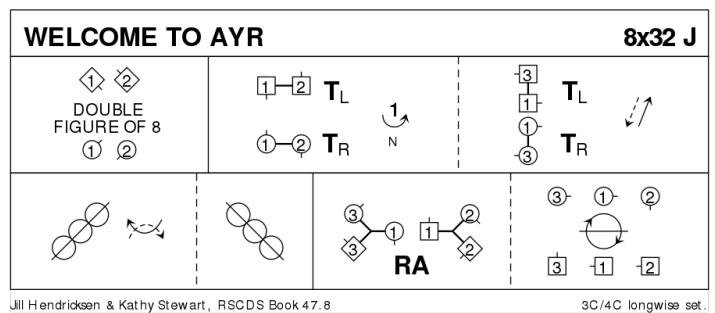

33 INVERCAULD'S REEL S32 · 3/4L

Alexander Bowman: RSCDS XI 10 · Crib: Eric Ferguson's E-cribs · Diagram: Keith Rose's Diagrams

- 1- 1c set | cast off (2c up) ; cross down between 3c and cast up to 2plx
- 9- 2c+1c R&L, 1c finish facing 1cnr
- 17- 1c set to and turn corners, finish between cnrs
- 25- Reels3{6} on the sides (Lsh to 1cnrs) | 1c cross (to 2,1,3)

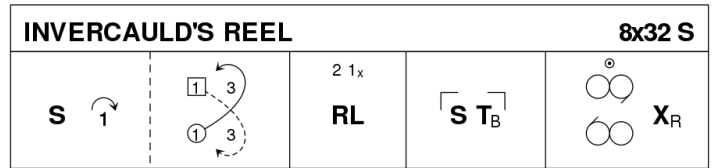

Alexander Bowman, 1758, RSCDS Book 11.10

3C/4C longwise set.

34 THE DEIL AMANG THE TAILORS R32 · 3/4L

RSCDS XIV 7 · Crib: Eric Ferguson's E-cribs · Diagram: Keith Rose's Diagrams

- 1- 1c+2c set, 1/2 RHA ; set, 1/2 LHA
- 9- 1c lead down the middle and up, 2c step in for
- 17- 1c+2c Allemande
- 25- 2c+1c+3c circle6 and back.

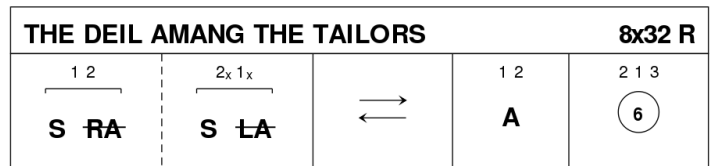

Davies Collection, RSCDS Book 14.7

3C/4C longwise set.